

# Study Guide for 25 Standards Every Inspector Should Know Course

This study guide can help you:

- take notes;
- read and study offline;
- organize information; and
- prepare for assignments and assessments.

As a member of InterNACHI, you may check your education folder, transcript, and course completions by logging into your Members-Only Account at [www.nachi.org/account](http://www.nachi.org/account).

To purchase textbooks (printed and electronic), visit InterNACHI's ecommerce partner Inspector Outlet at [www.inspectoroutlet.com](http://www.inspectoroutlet.com).

Copyright © 2007-2015 International Association of Certified Home Inspectors, Inc.



# Student Verification & Interactivity

## Student Verification

By enrolling in this course, the student hereby attests that s/he is the person completing all coursework. S/he understands that having another person complete the coursework for him or her is fraudulent and will result in being denied course completion and corresponding credit hours.

The course provider reserves the right to make contact as necessary to verify the integrity of any information submitted or communicated by the student. The student agrees not to duplicate or distribute any part of this copyrighted work or provide other parties with the answers or copies of the assessments that are part of this course. If plagiarism or copyright infringement is proven, the student will be notified of such and barred from the course and/or have his/her credit hours and/or certification revoked.



Communication on the message board or forum shall be of the person completing all coursework.

# Introduction

## Welcome

The purpose of this course is to teach 25 building standards and good practices related to inspecting systems and components in a residential dwelling. It is intended to raise the awareness and understanding of numerous building standards and good practices. Learning and understanding these standards will allow the inspector to effectively recognize defects in condition and installation.

And, in keeping with InterNACHI's commitment to Continuing Education, this course is open and free to all members, and can be taken repeatedly, without limit, if needed.

Comments and suggestions are appreciated. You may contact Ben Gromicko, InterNACHI Director of Education at [ben@internachi.org](mailto:ben@internachi.org).

## Standard #1: Electrical Panel

1. "Service" is a term used to describe the conductors and equipment for delivering electricity from the utility company to the wiring system of the building served. It is typically referred to as the main panel. The first point of disconnect for the conductors from the utility company is the service or main panel.
2. Only one service should be installed for each dwelling or building. A minimum 100-amp service is needed for a single residential dwelling unit.
3. The service panel is not allowed to be located inside a bathroom, over the stairs, or inside a clothes closet.
4. Refer to the following table:

<b>Service or Feeder Rating in Amps</b>	<b>Aluminum or Copper-Clad Aluminum Conductor (AWG)</b>	<b>Copper Conductor (AWG)</b>
100	#2	#4
125	1/0	#2
150	2/0	#1
200	4/0	2/0

5. Service entrance conductors must be protected from abrasion by the use of plastic bushings. Bonding bushings and jumpers are required to be used for metal conduit entering the panel enclosure through concentric or eccentric knockouts.
6. A means of disconnect for the service must be located either outside or inside the dwelling unit near the point of entrance of the service conductors. No more than six hand movements, or no more than six circuit breakers, may be used to disconnect all service. Typically, a main disconnect switch is required by the local authority. The main disconnect should be clearly marked to identify that it has the service disconnect.
7. A grounded conductor is a conductor that is grounded. The grounded conductor is commonly referred to as the neutral conductor. It is usually identified by white or gray insulation.
8. An ungrounded conductor is a conductor that is not grounded. The ungrounded conductor is commonly referred to as the hot or line conductor. It is usually identified by black or red insulation (any color other than green, white or gray).
9. A grounding electrode is a device that makes an electrical connection to the earth. A grounding electrode can be rebar in a footer, a copper underground water pipe with 10 feet of contact with the earth, or a grounding rod.
10. An equipment grounding conductor is used to ground the electrical equipment. The equipment grounding conductor is commonly referred to as the ground. These conductors are typically identified by green insulation, or the conductor is bare.

11. A grounding electrode conductor (GEC) is a conductor used to connect the grounding electrode to the equipment grounding conductor, the grounded conductor, or both at the service, at each building or structure that is supplied by a feeder or branch circuit, or at the source of a separately derived system. The GEC is a conductor used for grounding at the service or separate building. The GEC is used to connect to the grounding electrode system.



12. The main bonding jumper must be installed to connect the grounds and neutral bars and make connection to the enclosure.



13. All unused holes in the panel should be closed.

14. White insulated conductors that are used as ungrounded conductors or hots should be identified

at all termination points.

**15.** All 15- and 20-amp 120-volt circuits for dining rooms, living rooms, bedrooms, sun rooms, closets, hallways, or similar areas must be AFCI-protected.

**16.** Each cable should be secured to the panelboard enclosure using listed cable connectors.

## Others:

**17.** Sheet metal screws are not allowed for grounding connections.

**18.** Unused openings for circuit breakers should be closed.

**19.** Correct breaker types should be used for each panelboard, according to the manufacturer's label.

**20.** Each circuit should be clearly and specifically identified as to its purpose. No two circuits should be labeled the same. No circuit should be identified in a way that may be subject to change with occupancy. For example, no breaker should be labeled "Ben's bedroom."

**21.** An outlet is a point on the electrical wiring system where electrical current is taken to supply equipment. An outlet can be a wall receptacle, light fixture, smoke detector, or an appliance. A wall switch is not considered an outlet, since no current is taken at a switch; current is simply passing through.

**22.** A device is part of the electrical system that is intended (as its primary function) to carry or control electricity but not use electricity, such as a switch or a thermostat.

## Standard #2: Electrical Subpanel

1. Subpanels should be supplied with four conductors to isolate grounds and neutrals.
2. SER cables are commonly used to supply electricity to subpanels. A typical subpanel is commonly supplied by a 100-amp feeder using #2 AL SER cable or #4 CU SER cable.
3. The equipment grounding bar must be bonded to



the subpanel enclosure.

4. Each grounded conductor or “neutral wire” shall terminate on an individual terminal that is not also used for another conductor, except where the terminal is identified for connection of more than one conductor.
5. Multiple grounding conductors or “grounding wires” may be installed under the same terminal if they are the same size, and the maximum number of conductors does not exceed the recommendations of the panel manufacturer.
6. A bonding jumper to the neutral bar must not be installed.
7. A main breaker is not required for the subpanel if over-current protection is provided for the feeder conductors.

## Standard #3: Roofing Underlayment

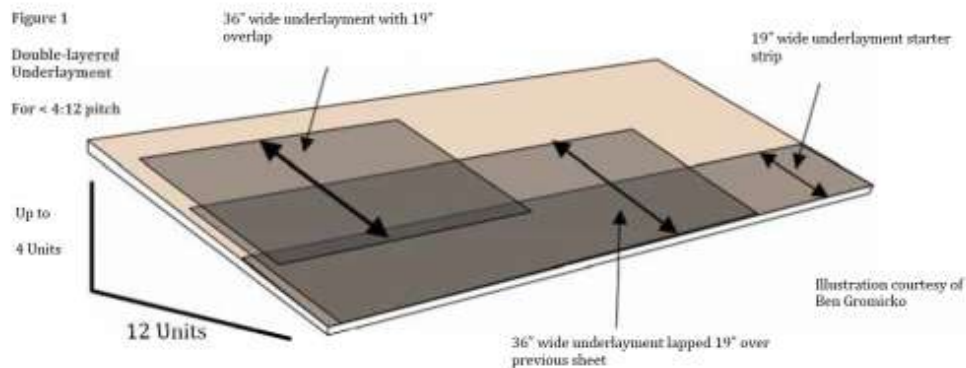

For roof slopes from 2:12 (two units vertical in 12 units horizontal = a 17% slope) to 4:12 (four units vertical in 12 units horizontal = a 33% slope), underlayment should be two layers applied in the following manner:

- A 19-inch strip of underlayment felt should be applied parallel to and starting at the eaves, and fastened sufficiently to hold in place. Starting at the eaves, 36-inch-wide sheets of underlayment should be applied, overlapping successive sheets 19 inches, and fastened sufficiently to hold in place.
- For roof slopes from 4:12 and greater, one layer of underlayment should be applied in a shingle-like

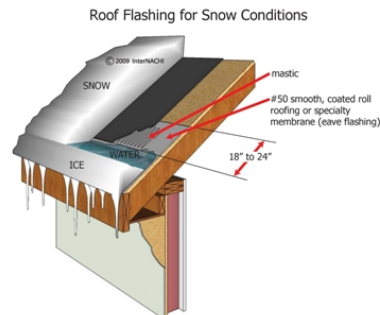

fashion. It should start from the eaves and run parallel to the eaves. It should overlap 2 inches. It should be fastened sufficiently to hold in place.

- The end-laps of the underlayment should be offset by at least 6 feet.

In areas where there is a history of ice forming along the eaves, causing a backup of water, an ice barrier that consists of at least two layers of underlayment cemented together, or a self-adhering, polymer-modified bitumen sheet, shall be used in lieu of normal underlayment, and extend from the lowest edges of all roof surfaces to a point at least 24 inches inside the exterior wall line of the building. Detached structures without conditioned areas are the exception.

## Quiz #1

The first point of disconnect for the conductors from the utility company is called the \_\_\_\_ or main panel.

- service
- fixture
- outlet
- line

A minimum service of \_\_\_\_ amps is required for a single residential dwelling unit.

- 100
- 60
- 200
- 125

T/F: It is acceptable for a service panel to be located inside a clothes closet.

- False
- True

If the service or feeder rating in amps is 200, then the aluminum AWG size should be \_\_\_\_\_.

- 4/0
- #2
- #4
- 2/0

An ungrounded conductor is commonly referred to as the \_\_\_\_ conductor.

- hot



- warm
- white
- neutral

All 15- and 20-amp 120-volt circuits for dining rooms, living rooms, bedrooms, sun rooms, closets, hallways, and similar areas in a home must be \_\_\_\_\_-protected.

- AFCI
- GFCI

T/F: A main breaker is not required for a subpanel if over-current protection is provided for the feeder conductors.

- True
- False

A grounded conductor is commonly referred to as the \_\_\_\_\_ conductor.

- neutral
- single
- hot
- black

T/F: For roof slopes from 2:12 to 4:12, two layers of underlayment should be applied.

- True
- False

T/F: In homes located in areas having a history of ice forming along the eaves, an ice barrier consisting of at least three layers of underlayment cemented together is required.

- False
- True

## **Standard #4: Glazing**

For the purpose of glazing, the following 12 areas are considered specific hazardous locations:

1. glazing in swinging doors, except jalousies;
2. glazing in fixed and sliding doors;

3. glazing in sliding and bi-fold closet doors;
4. glazing in storm doors;
5. glazing in all unframed swinging doors;
6. glazing in doors and enclosures for hot tubs, whirlpools, saunas, steam rooms, bathtubs and showers, and glazing in any part of a building wall enclosing these compartments where the bottom exposed edge of the glazing is less than 60 inches measured vertically above any standing or walking surface (be particularly careful in checking windows inside bath and shower assemblies);
7. glazing, in an individual fixed or operable panel adjacent to a door where the nearest vertical edge is within a 24-inch arc of the door in a closed position, and whose bottom edge is less than 60 inches above the floor or walking surface;
8. glazing in a panel, other than those locations described in items #6 and #7, that meets all of the following conditions:
  - 8.1. exposed area of an individual pane larger than 9 square feet;
  - 8.2. bottom edge less than 18 inches;
  - 8.3. top edge more than 36 inches above the floor; and
  - 8.4. one or more walking surfaces within 36 inches horizontally of the glazing;
9. all glazing in railings;
10. glazing in walls around swimming pools, hot tubs and spas where the bottom edge of the glazing is less than 60 inches above a walking surface, and within 60 inches horizontally of the water's edge;
11. glazing next to stairways, landings or ramps within 36 horizontal inches of a walking surface when the exposed surface of the glass is less than 60 inches above the adjacent walking surface;
12. glazing next to stairways within 60 horizontal inches of the bottom tread in any direction when the exposed surface of the glass is less than 60 inches above the nose of the tread. Glass block is considered masonry.

---

---

---

---

---

---

---

---

12. glazing next to stairways within 60 horizontal inches of the bottom tread in any direction when the exposed surface of the glass is less than 60 inches above the nose of the tread. Glass block is considered masonry.

These areas are hazardous because of their frequent impact by the building's occupants. Glazing located in doors is of particular concern because of the increased probability of accidental impact while operating the doors.

These areas are hazardous because of their frequent impact by the building's occupants. Glazing located in doors is of particular concern because of the increased probability of accidental impact while operating the doors. A person may often push against the glazed portion of a door in order to operate it. A large piece of glass located along a travel path where no barrier is provided is a dangerous area.

There are products and applications that are exempt from the requirements for hazardous locations, including small openings in doors through which a 3-inch-diameter sphere cannot pass, and specific decorative pieces, such as leaded glass.

## Standard #5: Garage Firewall

1. The door between an attached garage and a dwelling unit should be a solid wood door not less than 1-3/8 inches thick, a solid- or honeycomb-core steel door not less than 1-3/8 inches thick, or a 20-minute fire-rated door.

2. Although drywall or other approved material can provide a firewall separation at the walls and ceilings between the garage and the dwelling unit, openings that penetrate the separation should be appropriately protected.

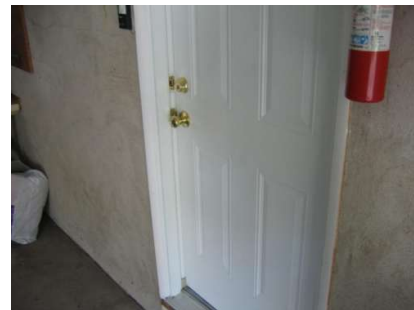

3. The type of door construction or the fire rating of the door is important. In many jurisdictions, a self-closing device on the door may be required. The entire door assembly may have to be fire-rated.

4. Where an air duct passes through the drywall (gypsum board) located on the garage side of the firewall separation, the duct material should be a minimum of #26-gauge sheet material. There should not be any openings in the ductwork within the garage area.

5. Without exception, all electrical receptacles in garages must be GFCI-protected.

A direct opening between an attached garage and a sleeping room is not permitted. That opening is hazardous.

# Standard #6: Garage Drywall

It is common for a fire to start in an attached garage. The fire may grow unnoticed by the occupants and become a significant hazard. Therefore, a minimum amount of fire protection is needed.

There should be at least 1/2-inch drywall (gypsum board) applied on the garage-side to separate the garage from the residence and its attic space. Garages located below a habitable room shall be separated by at least 5/8-inch Type X drywall (gypsum board) or equivalent.

This standard requires a minimum level of fire protection from the garage to the dwelling unit. It allows the occupants time to escape in case of a fire. The separation also restricts the spread of fire from the garage to the dwelling unit until the fire can be controlled and extinguished.

# Standard #7: Emergency Egress

Basements and every sleeping room should have at least one operable emergency escape and rescue opening that opens directly into a public street, public alley, yard or court.

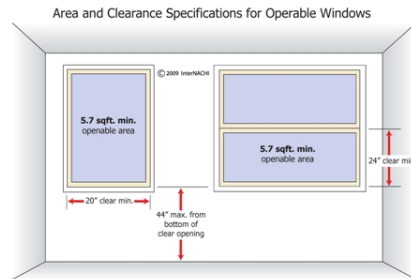
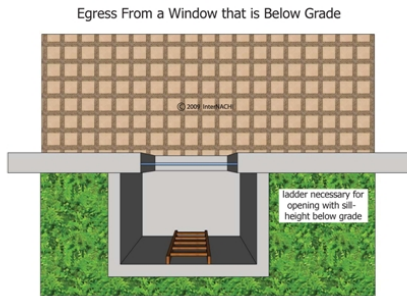

Where basements have one or more sleeping rooms, an emergency egress and rescue opening should be installed for each sleeping room, but is not required in adjoining areas of the basement. The sill height of the emergency escape and rescue opening should not be more than 44 inches above the floor.

---

---

---

---

---

---

---

---

---

---

Because many deaths and injuries are caused by occupants being asleep at the time of a fire, the standard requires that basements and all sleeping rooms have doors or windows that can be used for rescue or escape in an emergency. During a fire, the normal means of escape will mostly likely be blocked.

If the emergency escape and rescue opening has a sill height below ground level, a window well should be provided. The window well should have a horizontal area of at least 9 square feet, with a minimum horizontal projection and width of 36 inches (with the exception of a ladder encroachment into the required dimension).



If an emergency escape window is located under a porch or deck, the porch or deck should allow the window to be fully opened, and the escape path should be at least 3 feet in height.

## Quiz #2

T/F: Glazing in storm doors is considered a hazardous location.

- True
- False

T/F: Glass in bi-fold closet doors is considered a hazardous location.

- True
- False

Glass block is considered \_\_\_\_\_.

- masonry
- safety glazing
- hazardous
- double-glazing

T/F: Glazing in railings is considered a hazardous location.

- True
- False

T/F: The door between an attached garage and a dwelling unit should be of solid wood not less than 2 inches thick.

- False
- True

T/F: In many jurisdictions, a self-closing device on the door between the dwelling and the garage may be required.

- True
- False

T/F: In general, there should be no openings in the ductwork installed in a garage area.

- True
- False

T/F: It is common for fires to start in an attached garage.

- True
- False

There should be at least \_\_\_-inch gypsum board applied on the garage side to separate the garage from the residence and its attic space.

- 1/2
- 3/8
- 1
- 1/4

Garages located below a habitable room shall be separated by at least 5/8-inch Type \_\_\_ gypsum board or equivalent.

- X
- XL
- T
- SE

The \_\_\_\_\_ and every sleeping room should have at least one operable emergency escape and rescue opening that opens directly into a public street, public alley, yard or court.

- basement
- garage
- crawlspace
- bathroom

The sill height of an emergency escape and rescue opening should be no higher than \_\_\_ inches above the floor.

- 44
- 66
- 88
- 22

A window well should have a horizontal area of at least \_\_\_ square feet, with a minimum horizontal projection and width of \_\_\_ inches.

- 9... 36
- 10... 42
- 7... 32
- 4... 24

T/F: Under no circumstances should an emergency escape and rescue opening be located under a porch or deck.

- False
- True

## Standard #8: Drainage

Proper drainage of the building site is important in preventing wet basements, damp crawlspaces, erosion, and possible failure of the foundation. Proper drainage should include adequate slope of the ground directed toward drainage devices that are capable of carrying surface water runoff. Gutters and downspouts should direct roof water to appropriate drainage areas.



Surface water should be diverted to a storm sewer system or other drainage points. Building sites should be graded so as to drain surface water away from the foundation. The ground surface should slope a minimum of 6 inches within the first 10 feet. Drainage systems or swales are effective methods for controlling surface water, especially in areas where attaining the minimum grade is not possible.

## Standard #9: Anchorage

To prevent walls and floors from shifting under lateral loads, anchorage to the foundation is required. Anchor bolts can be used, as well as foundation straps, if installed in accordance with the manufacturer's instructions.

When braced wall panels are supported directly on a continuous foundation, the wall wood sill plate or cold-formed steel bottom track should be anchored to the foundation appropriately. The wood sole plate at exterior walls on monolithic slabs and wood sill plates should be anchored to the foundation with anchor bolts spaced no more than 6 feet on center.

There should be at least two bolts per plate section, with one bolt located not more than 12 inches, or less than seven bolt diameters, from each end of the plate section.

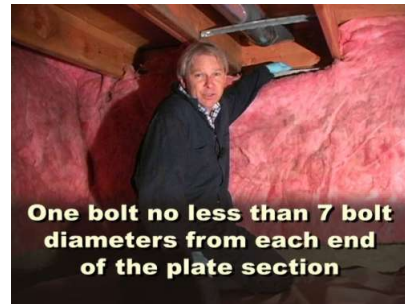

Bolts should be at least 1/2-inch in diameter and should extend at least 7 inches into masonry or concrete. There are some exceptions with straps and short walls connecting offset braced wall panels.

In some areas, large square plate washers are required to compensate for oversized bolt holes that are often bored.

---

---

---

---

---

---

---

---

---

---



## Standard #10: Notches and Holes

Notches can potentially reduce the structural integrity of solid lumber joists. Therefore, there are limits on the size and location of notches to solid-sawn lumber members.

Notches in solid lumber joists, rafters and beams should not be longer than one-third of the depth of the member ( $D/3$ ), and should not be located in the middle third of the span.

Notches at the ends of the member should not be more than one-quarter of the depth of the member ( $D/4$ ). Notches located in the outer thirds of the member should not be more than one-sixth of the depth of the member ( $D/6$ ).

If engineered wood members, such as trusses and I-joists, are notched, the effects of the notches must be planned and approved by the structural engineer who designed the member.

Bored holes in solid lumber members can have the same effect as notches. The bored hole can reduce the structural integrity of the member.

The diameter of bored holes into solid lumber members should not exceed one-third the depth of the member. Holes should be at least 2 inches from the top or bottom edge of the member, and should be at least 2 inches from any other hole or notch in the member.

## Standard #11: Masonry Chimney



A masonry chimney should terminate some distance above a roof in order to provide adequate upward draft in the chimney. Masonry chimneys should extend at least 2 feet higher than any portion of the building within 10 horizontal feet. The minimum height of the chimney should be 3 feet.

Cleanout openings should be provided within 6 inches of the bottom of the flue within the masonry chimney. There is an exception for cleaning a fireplace at the fireplace opening.

The upper edge of the cleanout should be located at least 6 inches below the lowest chimney inlet opening.

The height of the chimney's cleanout opening should be at least 6 inches.

The cleanout cover should not be made of combustible material.

Any portion of a masonry chimney located in the interior of the building (such as an attic space) should have at least 2 inches of air-space clearance from combustibles. As heat is transferred through the masonry material, any combustible material in close proximity to the heated walls may reach the point of ignition. The air space helps in the dissipation of heat.

Chimneys with a dimension parallel to the ridgeline greater than 30 inches that does not intersect the ridgeline should have a chimney cricket. The cricket should be flashed and counter-flashed in the same manner as a normal roof-chimney intersection.

## Standard #12: Attic Access

Mechanical equipment in an attic space or in an under-floor crawlspace should be accessible for service and removal.

1. In addition to an adequately sized access opening, a passageway should be provided. In an attic, the passageway should be made of solid flooring.
2. There should be an opening to the space and a clear, unobstructed passageway large enough to allow removal of the mechanical appliance. The passageway should be at least 30 inches high, at least 22 inches wide, and not more than 20 feet in length when measured along the centerline of the passageway from the opening to the appliance. There are some exceptions.
3. The opening should be at least 30 inches by 20 inches.
4. A service area is required in front of the mechanical equipment with a minimum dimension of 30 inches by 30 inches.
5. A light fixture should be installed to illuminate the passageway and the mechanical appliance.
6. A control switch should be installed near the entry to the passageway.
7. An electrical receptacle should be installed at or near the mechanical appliance to allow for safe and convenient maintenance and service of the appliance.



# Quiz #3

Proper \_\_\_\_\_ of a building site is important for preventing wet basements, damp crawlspaces, erosion, and possible failure of the foundation.

- drainage
- digging
- tree-planting
- cleaning

The ground surface around a building's perimeter should slope a minimum of \_\_\_ inches within the first \_\_\_ feet.

- 6... 10
- 12... 6
- 2... 24
- 10... 6

To prevent walls and floors from shifting under lateral loads, anchor bolts or \_\_\_\_\_ attached to the foundation are required.

- straps
- glue
- tape
- rope

Foundation anchor bolts should extend at least \_\_\_ inches into masonry or concrete.

- 7
- 12
- 2
- 10

T/F: Notches in solid lumber joists, rafters and beams should not be longer than one-third the depth of the member.

- True
- False

In a solid wood floor joist, a bored hole should be at least \_\_\_ inches from the top or bottom edge.

- 2
- 2-1/2
- 1-3/4

- 3

Masonry chimneys should extend at least \_\_\_ feet higher than any portion of a building within 10 horizontal feet.

- 2
- 18
- 6
- 10

The upper edge of a masonry chimney cleanout should be at least \_\_\_ inches below the lowest inlet opening.

- 6
- 8
- 4
- 10

Any portion of a masonry chimney located in the interior of the building (such as in an attic space) must have a clearance of at least \_\_\_\_\_ from any combustibles.

- 2 inches
- 4 inches
- 1 foot
- 1 inch

T/F: In an attic space, the passageway to mechanical equipment should be made of solid flooring.

- True
- False

T/F: The opening to an attic space that has any mechanical equipment located in it should be a maximum of 20 inches by 20 inches.

- False
- True

T/F: A light fixture should be installed in an attic to illuminate the passageway and any mechanical appliance located there.

- True
- False

# Standard #13: Clothes Dryer

Clothes dryer exhausts pose a different problem compared to other exhaust systems because the air they carry is damp and infused with lint. The exhaust of a dryer must vent outside and not discharge into an attic or crawlspace because the wooden structural members could be affected. Exhaust vents should have a backdraft damper installed to prevent cold air, rain, snow, rodents and pests from entering the vent.

The length of a clothes dryer exhaust ensures that the dryer exhaust blower will be able to push sufficient air volume to take away the damp air and lint. The length can be increased only when the make and model of the dryer is known, or when an approved blower fan calculation is provided.



*Clothes dryers should not exhaust into a crawlspace.*

The maximum length of a clothes dryer exhaust duct should not be greater than 25 feet from the dryer's location to the wall or roof termination. For each 45-degree bend, the maximum length of the duct is reduced by 2-1/2 feet. For each 90-degree bend, the maximum is reduced by 5 feet.

The maximum length of the exhaust duct does not include the transition duct.

Screens are not permitted on clothes dryer exhaust vents because they can trap lint and other debris, which poses a fire hazard.

# Standard #14: Standpipes

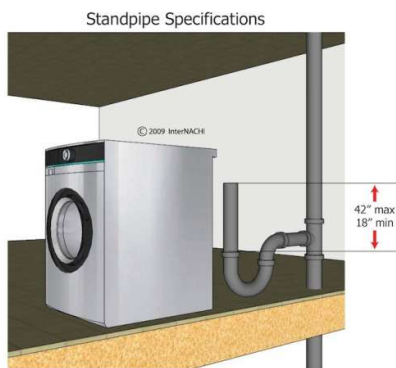

Standpipes should extend at least 18 inches and no more than 42 inches above the trap weir.

Access to all standpipes, traps and drains should be provided for cleaning and rodding. The standpipe itself is often concealed, but there must be open access at the point of indirect connection.

A laundry tray (tub) waste line is permitted to connect into a standpipe for the automatic clothes washer drain. This standpipe should not be less than 30 inches as measured from the crown weir. The outlet of the laundry tray should not be greater than 30 inches horizontally from the standpipe trap.

A standpipe can serve as an indirect waste receptor. To prevent overflow, the

height limitation is necessary to provide some retention capacity and head pressure. The height limitation controls the velocity of the waste flow at the trap inlet. The limitation is necessary when a high rate of discharge enters the indirect waste pipe, such as that from a clothes washer. Excessive velocity will siphon the trap.

## Standard #15: TPR Valve Discharge

An appliance used for heating water or storing hot water must be protected by a relief valve.

A combination temperature- and pressure-relief valve, or separate temperature-relief and pressure-relief valves, prevent a water heater from exploding. They are emergency devices. They are not intended to function continuously.



The pressure-relief valve should be set to open at least 25 psi above the system pressure, but not over 150 psi. The relief-valve setting should not exceed the tank's rated working pressure.

Temperature-relief valves should be installed within the top 6 inches of the tank. The valve should be set to open at a maximum temperature of 210° F.

Discharge from a relief valve should be immediately investigated. A discharge indicates that something is wrong with the system. The discharge point should be conspicuous.

---

---

---

---

---

---

---

---

---

---

## **There are 13 requirements for a discharge pipe serving a TPR valve:**

1. The pipe should not be directly connected to the drainage system.
2. The pipe should discharge through an air gap located in the same room as the water heater.
3. The pipe should be constructed of materials tested, rated and approved for such use.
4. The pipe should not be smaller than the diameter of the outlet of the valve served and should discharge full-size to the air gap.
5. The pipe should not have valves or T-fittings installed.
6. The pipe should not have a threaded end.
7. The pipe should serve a single relief device and should not connect to piping serving any other relief device or equipment.
8. The pipe should discharge to the floor, to an indirect waste receptor, or to the outdoors. Where discharging to the outdoors in areas subject to freezing, discharge piping should be first piped to an indirect waste receptor through an air gap located in a conditioned space.
9. The pipe should not terminate more than 6 inches above the floor or waste receptor.
10. The pipe should discharge in a manner that does not cause personal injury or structural damage.
11. The pipe should be installed so as to flow by gravity.
12. The pipe should discharge to a termination point that is readily observable by the building's occupants.
13. The pipe should not be trapped.

The termination of a relief valve discharge pipe should always be visible and conspicuous. An air gap is necessary to prevent backflow and contamination of the potable water system. The discharge pipe must not be reduced in size, and must not be less than the size of the relief valve outlet. A reduction in size will act as a restriction and would impede the flow of the discharge. Relief valves must not be exposed to freezing temperatures. The slow drip of a leaking valve in freezing

temperatures would cause ice to form and would restrict the discharge and disable the valve.

## Standard #16: Expansion Tank



When a water-heating appliance is connected to a water distribution system, migration of heated water into the water distribution piping is possible. In typical water distribution systems without some type of pressure relief, heated water will expand into the water service line and into the public main. If the expansion is not relieved or accommodated in the system, high pressure can develop that can damage pipe, components, and the water heater source.



For water service pipe sizes up to and including 2 inches, a device for controlling pressure shall be installed where, because of thermal expansion, the pressure on the downstream side of a pressure-reducing valve exceeds the pressure-reducing valve setting. A device for controlling pressure should be installed in a system that has a water-heating appliance and a backflow-prevention device, check valve, or other device, because thermal expansion will cause an increase in pressure.

## Standard #17: Roof Vents

An open vent pipe that passes through a roof should extend at least 6 inches above the roof.

---

---

---

---

---

---

---

---

---

---



If snow accumulation is expected at various times, the vent height should be increased so that the vent pipe will be at least 6 inches above the anticipated snow accumulation. The height in snowy areas is often determined by the local building official based upon local information. Most roofs are not designed for occupation, so the main concern is to simply vent the gases and odors above the roof.

If the roof is used for a purpose other than weather protection, such as a deck that can be occupied or an observation platform, the vent extensions should extend above the individuals occupying the roof, at least approximately 7 feet above the roof.

## Quiz #4

The maximum length of a clothes dryer exhaust duct should be no longer than \_\_\_\_\_ feet from the dryer's location to the wall or roof termination.

- 25
- 20
- 35
- 15

T/F: A screen is not permitted on the exhaust vent of a clothes dryer.

- True
- False

Standpipes for clothes washers should extend at least \_\_\_\_ inches and no more than \_\_\_\_ inches above the trap weir.

- 18... 42
- 22... 22
- 4... 12
- 12... 36

T/F: A standpipe can serve as an indirect waste receptor.

- True
- False

Any appliance used for heating water or storing hot water must be protected by a \_\_\_\_\_ valve.

- relief
- check
- stop

- backflow

T/F: TPR valves are emergency devices and are not intended to function continuously.

- True
- False

T/F: A device for controlling pressure should be installed in a system that has a water-heating appliance and a backflow-prevention device or check valve.

- True
- False

An open vent pipe should extend at least \_\_\_\_ inches above the roof.

- 6
- 9
- 12
- 3

## Standard #18: Traps

A trap (or water seal) keeps sewer gases from emanating out of the drainage system. A trap is a simple U-shaped pipe arrangement. The shape offers minimal resistance to the flow. The water seal prevents sewer gases and airborne bacteria from entering the interior air of the building.

The only type of fixture trap permitted is the P-trap. All other types, including bell traps, drum traps, S-traps, and traps with moving parts, are prohibited.

Traps shall have a water seal of at least 2 inches and, at most, 4 inches in depth. Traps for floor drains should be fitted with a trap primer or should be of the deep-seal design. Traps should be level with respect to the water seal. Traps should be protected from freezing. Trap seals should be protected from siphonage, aspiration and back-pressure by an approved venting system.

In general, each plumbing fixture should be separately trapped by a water seal trap. There are some exceptions when a trap is not required.

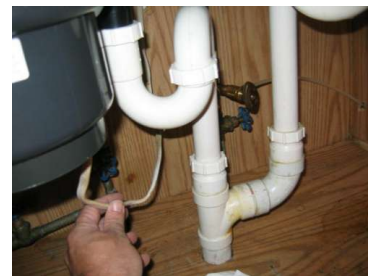

The vertical distance from the fixture outlet to the trap weir should not be greater than 24 inches. The limitation of the vertical distance is designed to control the velocity of the drainage flow. If the trap is located too far from the fixture, the trap may self-siphon the water out of the trap.

The horizontal distance from the fixture outlet to the trap weir should not be greater than 30 inches measured from the centerline of the fixture outlet to the centerline of the inlet of the trap.

It is desirable to locate the trap as close as possible to the fixture to avoid the need for a long drainpipe on the inlet side of the trap to be installed. There will not be enough flow energy to move waste if the horizontal distance exceeds this limit.

Fixtures must not be double-trapped because of the unnecessary additional restriction of flow and the increased potential for stoppages. Double-trapping can cause air to be trapped between the two trap seals, and the air-bound drain will block flow.

## **Standard #19: Panel Work Space**

There should be an adequate work space in front of the electrical panel. The space shall be at least 36 inches deep. The work space is needed to allow for safe clearance from any live components. It also provides enough room for the free movement of a person who needs to examine, adjust, service or maintain the electrical equipment.

The work space should be at least 30 inches in width in front of the electrical equipment, and not less than the width of the electrical equipment. If the panelboard is wider than 30 inches, the work space must extend its full width.

The work space should be clear of obstructions. The work space's height from the floor or platform should be at least 6-1/2 feet.

A space directly over a panelboard that extends from the top of the panelboard to the structural ceiling, or to a height of 6 feet above the panelboard -- whichever is lower -- should be provided. The space should be of equivalent width and depth of the electrical equipment. This dedicated space above the electrical equipment should be kept clear of components not related to the electrical equipment, such as plumbing pipe, HVAC ducts, etc. There should not be any interference with the direct run of cables and/or conduits to the electrical equipment. A suspended ceiling (with removable panels) may encroach into this dedicated space above the panelboard.

There must be access provided to the work space at the panel. The work space must not be designated for storage. Panelboards and overcurrent protection devices must

not be located in clothes closets, bathrooms, or over stairway steps. The work space must have manually-controlled, artificial illumination installed.

## Standard #20: Electrical Service Conductors

Open electrical service conductors and multi-conductor cables that are not installed in a raceway or provided with an approved overall outer jacket should have a clearance of at least 3 feet from the sides of doors, porches, decks, stairs, ladders, fire escapes and balconies, and from the sides and bottoms of operable windows.

The 3-foot clearance is based on the close proximity of people to the service conductors. The clearance reduces the potential for damage to the service conductors, and reduces the risk of accidental contact with the electrical conductors.

The clearance from windows that can open applies only to the sides of the window and below the window opening. Service conductors and drip loops located above a window opening are considered to be out of reach.

No clearance is required from windows that do not open.



Electrical service conductors should have a vertical clearance of at least 8 feet above the roof surface. There are exceptions.

---

---

---

---

---

---

---

---

---

---

The 8-foot vertical clearance above the roof surface should also be maintained for at least 3 feet horizontally from the edge of the roof, except when the service drop is attached to the side of the building. The 8-foot clearance may be reduced to 3 feet where the slope of the roof is 4:12 or greater, because there will likely be minimal travel across a roof with such a steep slope. The clearance may need to be increased (more than 8 feet in height) if the roof deck is expected to accommodate occupants, such as in the case of a rooftop court or sun deck, or where the roof is also the upper deck of a parking garage.

For service-drop cables supported on and cabled together with a grounded bare messenger wire, the vertical clearance should be at least 10 feet at the electrical service entrance to buildings, at the lowest point of the drip loop of the building's electrical entrance, and above areas and sidewalks accessed only by pedestrians. Where there is no anticipated vehicle traffic, a 10-foot minimum vertical clearance is needed. Where vehicles are present, higher clearances are needed. The vertical clearance should be at least 12 feet above a residential property (yards and grounds) and driveways. The vertical clearance should be at least 18 feet above public streets, alleys, roads and parking areas that are all subject to truck traffic.

## **Standard #21: Particleboard Sheathing**

Particleboard can be used to function as part of a wall system. The grade mark designates the use of the material as wall sheathing. Standards allow two grades: M-1 exterior glue and M-2 exterior glue. The grade mark with type M-1 or M-2 should be present on the particleboard.

The panels should not be exposed to the weather. Particleboard tends to absorb moisture and swelling can occur. Standards require protection, and inspectors should check for weather protection.

If the panel is 3/8-inch thick and its grade is type M-1, the maximum stud spacing is 16 inches on center when the siding is nailed to the studs.

If the panel is 1/2-inch thick and its grade is type M-2, the maximum stud spacing is 16 inches on center when the siding is nailed to the studs, or when the siding is nailed to sheathing.

If the panels are applied in a horizontal pattern across the wall, the end joints should be offset so that four panel corners do not meet.

All edges of the panel should be supported. Fire-blocking or equivalent framing members can be installed as intermediate edge supports. The inspector should

check the bearing of the panel edges on the studs. At the studs, the panel edges should have equal bearing.

The particleboard wall sheathing should have 1/16-inch gaps between each adjoining panel edge. A 1/16-inch gap should be left between panel edges.

The nails at the particleboard panels should not be too close to the edge of the panel. The nailing should not be closer than 3/8-inch from any edge of the panel. Nails must be at least 3/8-inch from the edges for proper holding capacity.

If the panel is 5/16-inch to 1/2-inch thick, then 6D common nails should be used. The nails should be spaced 6 inches on center at the edges, and 12 inches on center at the intermediate supports. There are also alternate attachment methods that are acceptable.

## Quiz #5

If a roof is used for a purpose other than weather protection, the vent extensions should extend above the roof by at least \_\_\_ feet.

- 7
- 20
- 3
- 12

A \_\_\_\_\_ prevents sewer gases from emanating from the drainage system.

- trap
- vent
- lateral
- drain stopper

The only type of fixture trap permitted is a(n) \_\_\_-trap.

- P
- bell
- S
- drum

T/F: If a panelboard is wider than 30 inches, the workspace in front of it must extend its full width.

- True
- False

T/F: The dedicated space above an electrical panel should be kept clear of components not related to the electrical equipment.

- True
- False

Open electrical service conductors and multi-conductor cables that are not installed in a raceway or provided with an approved overall outer jacket should have a clearance of at least \_\_\_\_ feet from the sides of doors, porches, decks, stairs, ladders, fire escapes and balconies, and from the sides and bottoms of operable windows.

- 3
- 1
- 2
- 10

\_\_\_\_ clearance is required from windows that do not open.

- No
- A 10-foot
- A 5-foot

For service-drop cables supported on and cabled together with a grounded bare messenger wire, the vertical clearance should be at least \_\_\_\_ feet at the electrical service entrance to buildings, at the lowest point of the drip loop of the building's electrical entrance, and above areas and sidewalks accessed only by pedestrians.

- 10
- 14
- 18
- 24

If particleboard is used as wall sheathing, the grade mark with Type \_\_\_\_ or \_\_\_\_ should be stamped on it.

- M-1... M-2
- C-3... N-4
- M-T... T-2
- CX... TX

# Standard #22: TPR and Explosive Power

In order to properly sense the tank's water temperature, the TPR valve should be located in the tank water in the upper 6 inches of the hot water tank, where all of the hottest water is located. The location is more important for temperature than for pressure, since the pressure is uniform throughout the tank. To prevent heating the water above 210° F, the TPR valve must be installed in the hot water within the top 6 inches of the tank. Water heater tanks usually have an opening in the tank shell installed by the manufacturer.



Water is essentially an incompressible solid. It has no latent heat energy within itself to expand when released, unless the water is super-heated. Water hotter than 212° F is considered super-heated water, and super-heated water wants to change into steam at atmospheric pressure. It possesses latent heat energy which can flash into steam and create a force that is not unlike an explosion.

Water would normally boil at 212° F, but inside a tank, it can't expand anywhere, so it can't boil off into steam. Water in a closed system and under pressure, such as inside a hot water tank, has a much higher boiling point. For example, where water supplied to a tank is at 50 pounds per square inch (psi), the boiling point is 297.7° F. Let's assume a water heater tank has 30 gallons of super-heated water inside it. Assume the capacity is 50 psi and the water temperature is super-heated at 300° F.

---

---

---

---

---

---

---

---

---

---



Remember that super-heated water wants to change into steam. If the tank ruptures, then 30 gallons of super-heated water will instantaneously turn into steam in an outward direction through the rupture. There is a tremendous amount of energy released as the super-heated water is exposed to atmospheric pressure, and it immediately turns into steam. Every cubic inch of water becomes a foot of steam!

Below is a chart showing the explosive energy created in a 30-gallon hot water tank at various pressures and temperatures.

Note (table below) that at 50 psi, water flashes into steam at 297.7° F, and the energy released equals more than 2 million foot-pounds of energy, similar to the explosive energy released by 1 pound of nitroglycerin. To further understand this power, a 16-inch gun on the battleship *U.S.S. Iowa* produced 7.5 million foot-pounds of energy.

Pressure per square inch (psi):			Foot-pounds of energy released when 30 gallons of water is exposed to atmospheric pressure:
212.0° F	10	479,800	
	50	2,021,900	
316.0° F	90	3,138,400	

This is why it is essential to avoid excessively high water temperature and pressure at a water heater tank.

## Standard #23: FVIR

"FVIR" stands for flammable vapor-ignition resistance.

In 2003, a new standard for water heaters was developed and phased in. It states: "The water heater should not ignite flammable vapors outside the water heater created by the spilling of gasoline onto the floor." The Consumer Product Safety Commission found that thousands of fires, injuries and deaths are related to water heaters. Most of these incidents were caused by improper storage or handling/spillage of gasoline.

If the tank is in compliance with the FVIR standards, it does not have to be raised 18 inches in garages or similar locations, unless required by the manufacturer or local code authorities.

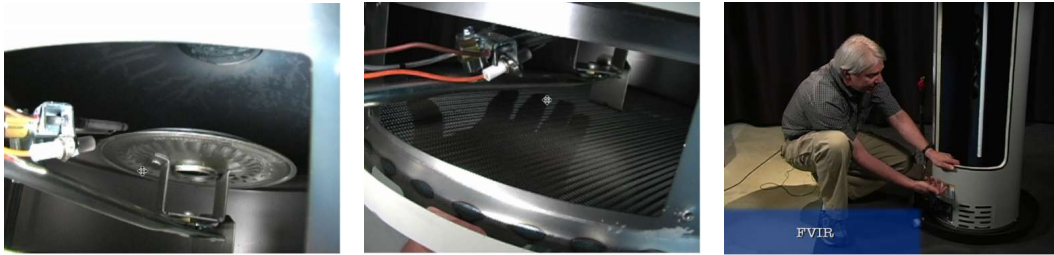

## **An FVIR water heater has the following components:**

- 1) a device to prevent ignited vapors from passing out of the combustion chamber;
- 2) a one-way intake system to control the movement of make-up air into the combustion chamber; and
- 3) an inner door and burner assembly to create a sealed junction with the combustion chamber, preventing combustion air and flammable vapors from entering the chamber through the front of the water heater.

## **All FVIR water heater tanks have the following characteristics in common:**

- 1) a flame arrestor plate. Located under the burner, this metal plate is designed to allow combustion air into the combustion chamber while keeping the flames from escaping downward and igniting flammable vapors below;
- 2) a thermal cut-off switch. It is designed to shut down the heater if it senses excessive temperatures caused by inadequate combustion air inside the chamber.

---

---

---

---

---

---

---

---

---

---

Inadequate combustion air can be caused by an explosion of flammable vapors, inadequate venting, inadequate make-up air, or the accumulation of lint, dust or oil on the screen; and

3) a lint, dust and oil screen. The screen is designed to protect the combustion process from lint, dust and oil. The screen openings can become clogged, especially when the tank is located in a basement or utility room.

## FVIR System on a Bradford White Defender Water Tank

During normal operation, air for combustion is drawn into the water heater through the openings in the jacket. This air travels down and around the combustion chamber and enters through holes in the very bottom of the corrosion-resistant

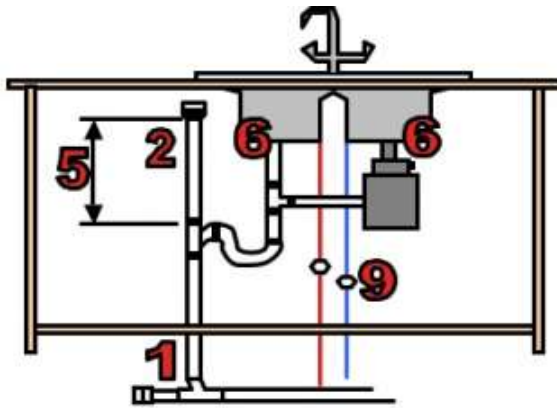

combustion chamber. The air then travels up through the oriented flame-arrestor plate louvers, where the velocity of the air is increased and its direction altered. The air then mixes in a normal manner with the supplied gas and is efficiently combusted, producing very low NO<sub>x</sub> (nitrogen oxide) emissions.

In the case where trace amounts of flammable vapors are present in the air flowing into the chamber, the vapors are harmlessly ignited by the burner/pilot flame. If flammable vapors are present in sufficient quantity to prevent normal combustion, the burner/pilot flame is shut down.

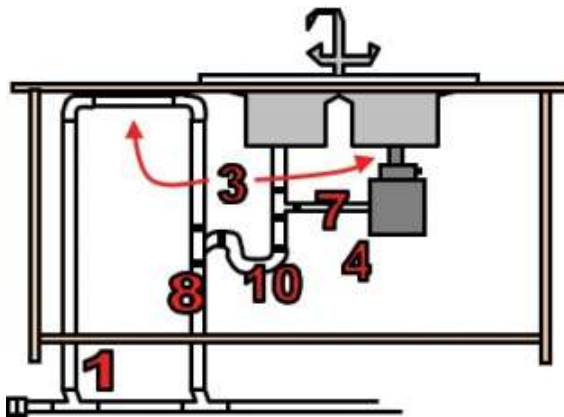

Should the flammable vapors continue to the burner, the flame arrestor plate prevents the flames from traveling backward and igniting vapors outside of the combustion chamber. The calibrated, multi-purpose thermal switch recognizes this and shuts down the pilot and main

burner. This switch also de-activates the burner and pilot in the unlikely event of restricted air flow caused by severe lint, dust or oil accumulation on the arrestor plate.

# Standard #24: Island Fixture Venting

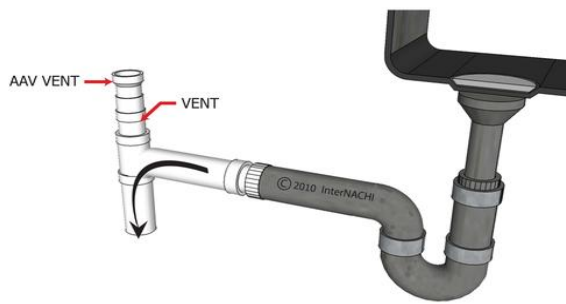

1. A cleanout should be installed for the island fixture vent pipes to provide access for rodding, cleaning and maintenance of all vent pipes below the flood-level rim of the fixtures.

2. Air-admittance valves are permitted on vent fixtures at island structures in kitchens.

3. Island vents should extend vertically above the drainage outlet of the fixture that is being vented before venting downward (vertically or horizontally).

4. Island fixture venting should not be installed for a fixture other than a sink or lavatory. Such a fixture is permitted with a dishwasher waste connection, a food waste grinder, or both.

5. Air-admittance valves are pressure-activated, one-way mechanical vents. They are used when venting through the building's roof structure is not available. This type of vent is common for kitchen sinks, especially when the fixture is installed in an island structure. When waste water is discharged, the valve opens, releasing a vacuum, and air is allowed to enter the vent for proper drainage.

The air-admittance valve should be installed between the most downstream fixture drain and the stack. A relief vent should be attached to the horizontal drain. The air-admittance valve should be installed at least 4 inches above the fixture drainpipe. Air-admittance valves should be installed after the drain-waste-vent (DWV) piping is tested. Air-admittance valves should not be installed in return-air plenums or supplies.

6. Waste outlets for sinks should be 1-1/2 inches minimum. The sink should have a strainer or crossbar to restrict the clear opening of the outlet.

7. The drainpipe for the food waste grinder should be at least 1-1/2 inches.

8. A dishwasher, food grinder and kitchen sink can all discharge into the same 1-1/2-inch waste drainpipe.

9. The branch water supply line for the dishwasher and kitchen sink should be at least 1/2-inch pipe. The hot should be installed on the left, and the cold on the right.

10. The size of the P-trap drainpipe should be at least 1-1/2 inches.

# Standard #25: Shingle Roofs and High Winds

When composition shingles are not securely attached, they can be damaged or torn away by high winds. When this happens, the interior of the structure becomes vulnerable to rainwater infiltration.

If the composition-shingle roof is repaired or replaced, the roofing contractor should make sure that the following requirements have been met:

- 1) Each shingle should be held by at least six nails or staples, which should be installed below the edge of the upper overlapping row of shingles.
- 2) A waterproof underlayment should be installed beneath the shingles. When securely attached, it temporarily protects the building from rain if shingles are torn away by the wind.
- 3) The roof sheathing (typically, plywood panels) should be at least 15/32-inch thick and should be securely attached to the roof trusses. Nails in older wood roof sheathing are often farther apart than recommended, especially in areas subject to high winds. The roofing contractor should check with local building officials for nailing requirements.



The benefits of this standard help prevent damage to a structure and its contents, as well as injuries to occupants.

---

---

---

---

---

---

---

---

---

---

If an old roof is going to be replaced, the roofing contractor should remove the existing shingles and underlayment, rather than install new shingles over them. This approach allows the contractor to inspect the sheathing and make any repairs that may be necessary.

All nails and staples used to attach the roof sheathing must penetrate the underlying roof trusses; otherwise, the sheathing will not be securely attached and can be more easily torn away by high winds. Inadequate attachment of roof sheathing resulting from poor workmanship is a common cause of roof failures during hurricanes and other storms with high winds.

If the building is in a hurricane-prone area, the following precautions are recommended:

- 1) Shingles should be attached with nails instead of staples.
- 2) The first course of shingles should be sealed to the starter strip with dabs or bands of roof cement.
- 3) If the building is within 3,000 feet of saltwater, the nails should be hot-dip galvanized or stainless steel.

## Quiz #6

The TPR valve should be located in the upper 6 inches of a hot water tank, where the \_\_\_\_\_ water is located.

- hottest
- oxidated
- rusty
- coldest

The 2003 standard for water heaters states: "The water heater should \_\_\_\_\_ flammable vapors outside the water heater created by the spilling of gasoline onto the floor."

- not ignite
- block
- ignite

All FVIR water tanks have components in common, including the \_\_\_\_\_.

- flame-arrestor plate
- flame-resistor plate
- arrestor hot plate

- flame-deflector plate

T/F: Air-admittance valves are permitted to vent fixtures installed at island structures in kitchens.

- True
- False

Air-admittance valves are \_\_\_\_\_-activated.

- pressure
- electronically
- voice
- temperature

In high-wind installations, each composition roof shingle should be held by at least \_\_\_\_\_ nails or staples.

- six
- two
- eight
- four

If a building is located in a hurricane-prone area, the first course of shingles should be \_\_\_\_\_.

- sealed to the starter strip with roof cement
- nailed to the starter strip
- doubled
- stapled to the starter strip

If a building is located within 3,000 feet of saltwater, the roofing nails should be \_\_\_\_\_ or stainless steel.

- hot-dip galvanized
- doubled in number
- aluminum-glazed
- copper

---

---

---

---

---

---

---

---